



Underwing Deicer – UWD

The Underwing Deicer (UWD) is designed to facilitate remote de-icing with aircraft engines running. UWD takes over tasks like under wing and landing gear de-icing on aircraft, normally performed by heavier, less manoeuvrable and more expensive equipment.

Working from an enclosed cabin, the operator is maximally protected against splashes of de-icing fluid, harsh winter environment and possible aircraft engine blast/induction.

The unit is built on a standard pickup truck. It is equipped with a stainless steel tank, a hydraulic pump and a diaphragm pump for handling of all types of fluid. As an option electrical heater and flow meter/counter are available.

The complete UWD fluid system, the nozzle and its suspension are Elephant® standard allowing interchangeability of spare parts from other Elephant® deicers.



The folding swing-arm can operate horizontally and vertically. The nozzle and swing-arm are operated by a single joystick, mounted on a center console in the driver's cab.



MAJOR ADVANTAGES

- Excellent supplement to other deicers operating in extreme weather conditions
- Designed to operate while aircraft engines are running
- Elephant® standard nozzle and fluid system
- Unsurpassed unit life time and low maintenance costs



Vestergaard Company A/S
 Skullebjerg 31 • Gevinge
 DK-4000 Roskilde • Denmark
 Tel: +45 4642 2222
 Fax: +45 4642 2232
 sales@g-vestergaard.dk
 www.g-vestergaard.dk

Vestergaard Company Inc.
 PO Box 280
 McHenry IL 60051 USA
 Tel: +1 815-759-9102
 Fax: +1 815-759-9103
 Toll free: +1 888-759-9118
 usa@g-vestergaard.com

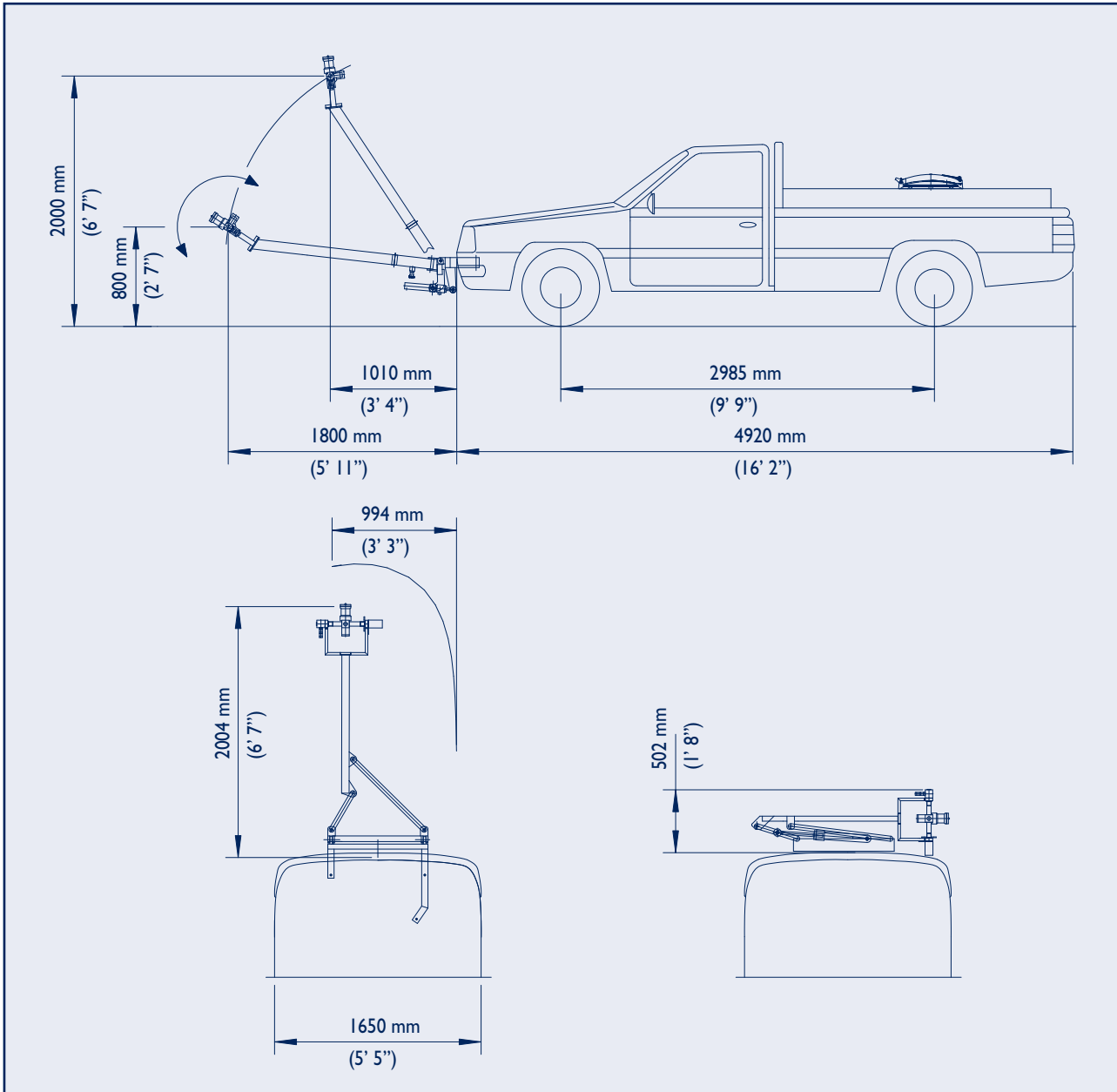

Specifications

Max. nozzle height:		2.0m (6'2")
Nozzle turning radius:	Horizontal	45°
	Vertical	90°
Max. tank capacity:		1000 liter (260 Gal(US))
Fluid pump capacity:		100 l/min. (10 bar) (26 Gal(US)/min.)
Suitable standard pick-up chassis e. g. GMC Sonoma		