



Medium Vacuum Toilet Service Unit - MVTS

The MVTS provides efficient and compact handling to airport operators having high traffic peaks. Due to its overall dimensions, the MVTS is extremely manoeuvrable in narrow areas and is excellent for service of all commuters and narrow body aircraft, as well as most mid-sized aircraft.

The MVTS is constructed exclusively from first class components. It is built on a standard truck chassis of customers' choice which ensures availability of spare parts and easy maintenance. All major components of vacuum, fluid, hydraulic and electrical systems are standard and thoroughly tested.

Large hinged doors ensure great accessibility to the machine room. Parts and cables are marked according to the diagrams to facilitate maintenance.

A user friendly control panel gives the operator a clear view of all the necessary functions.

The stainless steel tanks are placed in the centre of the vehicle and are accessible through manholes. The tank can be actively cleaned when dumping the waste through the hydraulic valve.

Fluid system and tank section are fully insulated for winter protection, and optional anti-freeze heater systems are available. To protect the couplings from freezing, a coupling heater can be placed in the basket. The optional steam generator removes ice from the aircraft hatch and piping.



MAJOR ADVANTAGES

- *Powerful vacuum evacuation system for ultimate efficiency and safety*
- *Reduced time and cost per operation*
- *Reduced manpower consumption*
- *Hygienic operator's environment*
- *Reduced demand for flush*
- *Prevents blockages, leakages and formation of ice at aircraft valves*
- *Unsurpassed unit lifetime and low maintenance costs*
- *High manoeuvrability and compact size for operation at narrow sites*

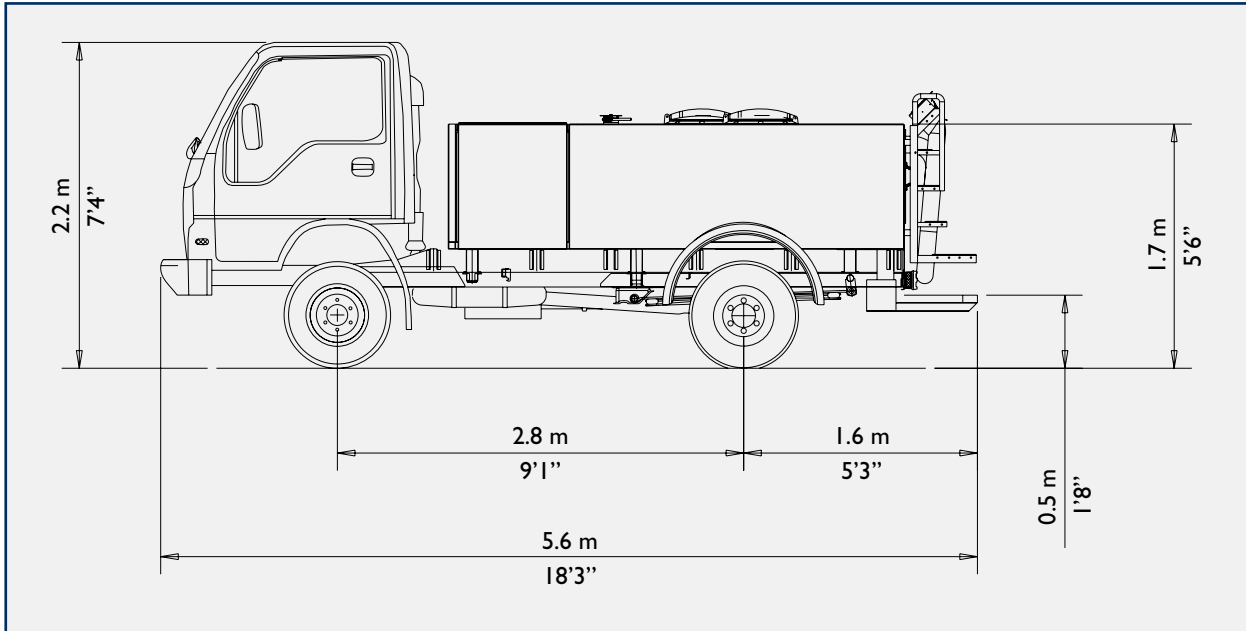

Specifications

Max. vacuum: 0.25 bar (3.5 psi) differential pressure (reached within 10-12 sec.)
 Max. flushing flow: 100 l/min. @ 3,5 bar (50 psi)
 Waste tank capacity: 1200 litres (317 gal US)
 Flush tank capacity: 1000 litres (264 gal US)
 2 – 3 tank configuration
 Tank section insulated for winter operations
 Return suction in flush line

Optional features:

Electrical level indicators with low level shut-down
 Heating systems
 Steam generator for de-icing of service point
 PLC-controlled
 Standard 6-7.5 ton truck chassis
 Elevating platform, giving basket floor height of up to 2.5 m (4 m work height)

Chassis Cabin Panel

- PTO on/off switch
- Control light for engaged PTO

Control Panel

- Water/disinfectant on/off
- Vacuum pump on/off
- Vacuum valve open/close
- Emergency stop
- Fluid counter with flowmeter
- Counter reset
- Hose rewind