



Small Vacuum Toilet Service Unit – SVTS

The SVTS is the perfect choice for operations requiring swiftness and tank sizes up to 400 litre.

The SVTS is constructed exclusively from first class components, built on a standard truck chassis ensuring availability of spare parts and easy maintenance. All major components of vacuum, fluid, hydraulic and electrical systems are standard, thoroughly tested and documented on drawings.

Large hinged doors ensure great accessibility to the machine room. Parts and cables are marked according to the diagrams to facilitate maintenance.

A user friendly control panel gives the operator a clear view of all the necessary functions.

The stainless steel tank is placed in the centre of the vehicle and is accessible through a man-hole.

Fluid system and tank section can be fully insulated for winter protection, and optional anti-freeze heater systems are available. To protect the coupling from freezing, a coupling heater is available. The optional steam generator removes ice from the aircraft panel and piping.



MAJOR ADVANTAGES

- Powerful vacuum evacuation system for ultimate efficiency
- Easily manoeuvrable and compact size unit
- Prevents blockages, leakages and formation of ice at aircraft valves
- Reduced demand for flush
- Reflux of flush line
- Reduced time and cost per operation
- Reduced manpower consumption
- Hygienic operator's environment
- Unsurpassed unit life time and low maintenance costs

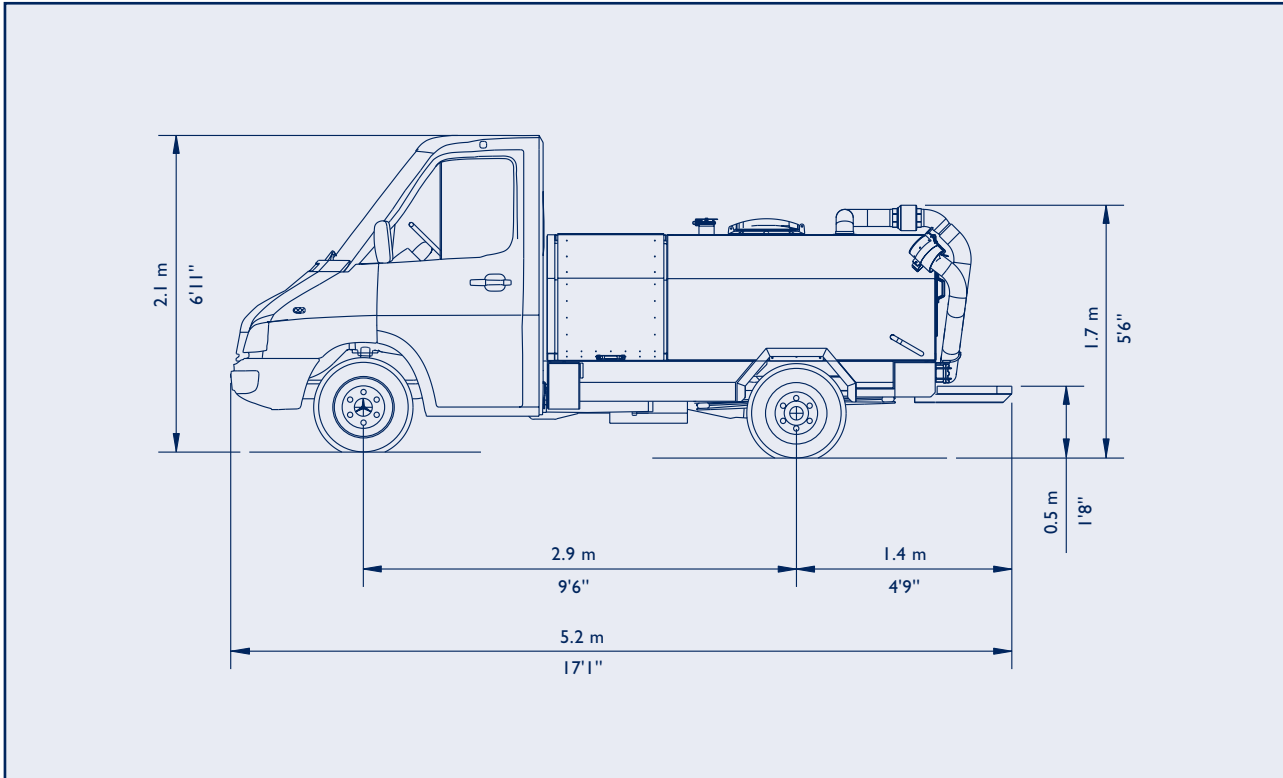

Specifications

Max. vacuum: 0.25 bar (3.5 psi) differential pressure (reached within 10-12 sec.)
 Max. flushing flow: 90 l/min. @ 3,5 bar (50 psi)
 Waste tank capacity: 400 litre / 100 gal US
 Flush tank capacity: 150 litre / 40 gal US (option for additionally 250 litre / 66 gal US)
 2 - 3 tank configuration at total 800 litre / 200 gal US

Tank section optionally insulated for winter operations

Return suction in flush line

Optional heating systems

Optional steam generator for de-icing of service point

Standard truck chassis (Mercedes Sprinter 311 CDI, Isuzu NPR or similar)